

Sellos Mecánicos de Cartucho TSSC-C03 45mm-120mm

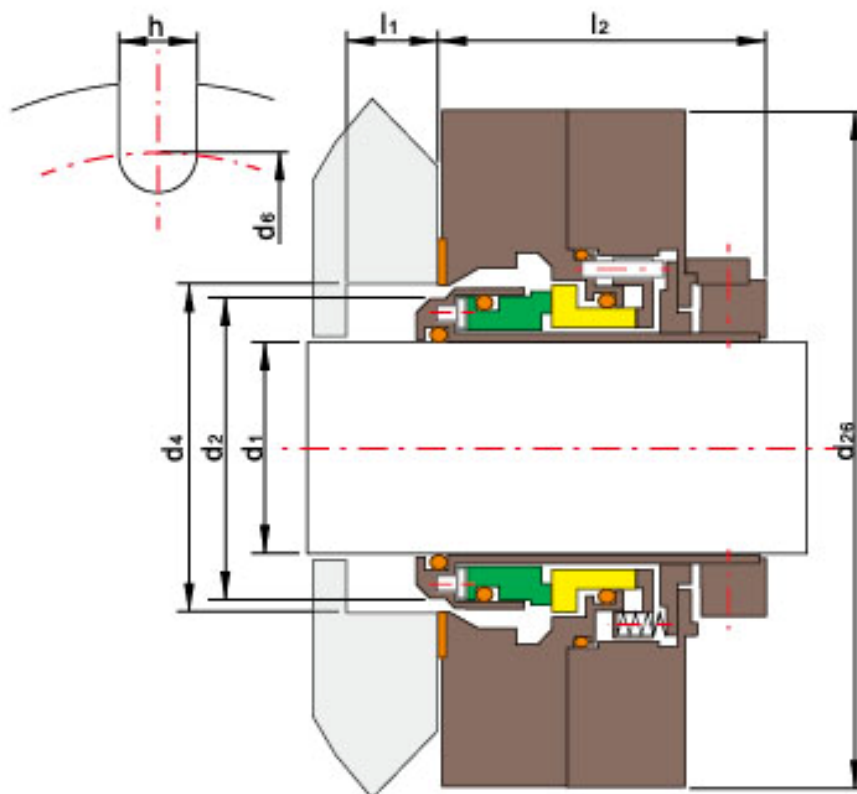

Características:

Shanghai Trisun Parts Manufacture Co.,Ltd.

Oficina central en Shanghai:

Oficina 05-06, Piso 16th, Edificio Hongjia, Calle Fushan No.388 (Cerca de la Calle Xiangcheng), Pudong, Shanghai, China.

Código Postal: 200122

Tel.: +86-21-58355541,+86-21-58353145,+86-21-58353343

Fax: +86-21-58353141

Correo Electrónico: trisun24@trisunltd.com

Límites de Funcionamiento:

Presión: ≤4MPa

Velocidad: ≤20m/s

Temperatura: -40°C~+204°C

1. Anillo Rotatorio (SiC/TC)
2. Anilla Estacionaria (SiC/Carbón/TC)
3. Anilla Estacionaria (VITON/AFLAS/Kalrez)
4. Otras Piezas (C-276/Dúplex/316)

d ₁ (pulgadas)	d ₂		d ₄	d ₆	d ₂₆	l ₁			l ₂	h
	Mín.	Máy.				3/8"	1/2"	5/8"		
45	64	73	18	13	139	49	95	97	-	43
48	67	73	18	13	139	49	95*	97*	-	43
50	69	78	18	13	139	49	100	102	-	43
53	73	87	18	17	152	49	109	111	115	43
55	74	83	18	17	152	49	105	107	111	43
58	80	91	18	17	152	49	114	116	120	43
60	80	91	22	17	152	49	114	116	120	43
65	92	103	22	17	164	64	127	131	-	45
70	96	111	22	17	196	64	137	141	-	45
75	102	119	22	17	202	64	143	147	-	45
80	106	122	22	17	203	64	150	154	-	45
85	111	128	22	21	211	64	152	156	161	45
90	116	132	22	21	214	64	160	164	168	45
95	121	137	22	21	221	64	161	165	170	45
100	127	144	22	21	228	64	168	172	177	45
110	137	154	22	21	237	64	178	182	186	45
120	146	164	22	21	266	64	187	191	195	45

Shanghai Trisun Parts Manufacture Co.,Ltd.

Oficina central en Shanghai:

Oficina 05-06, Piso 16th, Edificio Hongjia, Calle Fushan No.388 (Cerca de la Calle Xiangcheng), Pudong, Shanghai, China.

Código Postal: 200122

Tel.: +86-21-58355541,+86-21-58353145,+86-21-58353343

Fax: +86-21-58353141

Correo Electrónico: trisun24@trisunltd.com