

## Sellos Mecánicos de Cartucho TSDC-A02 24mm-125mm

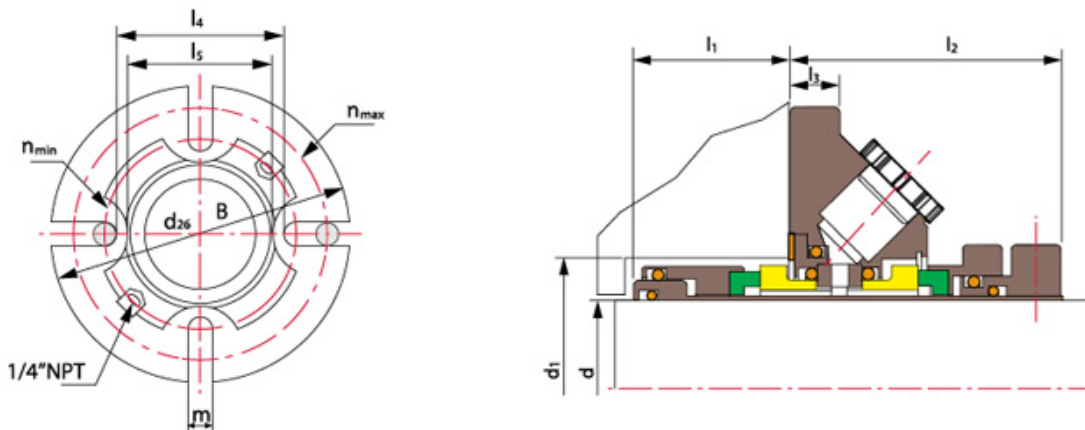

### Límites de Funcionamiento

Presión: <math>< 2.1 \text{ MPa}</math> (diámetro del eje  $\leq 75 \text{ mm}</math>)  
<math>< 1.3 \text{ MPa}</math> (diámetro del eje  $> 75 \text{ mm}</math>)$$

Velocidad:  $\leq 25 \text{ m/s}</math>$

Temperatura:  $-30^\circ\text{C} \sim +205^\circ\text{C}</math>$

Anillo Rotatorio (SiC/Carbón/TC)

Anilla Estacionaria (SiC/TC)

Sello Secundario (VITON/Anillo Encapsulado/PTFE)

Otras Piezas (SUS304/SUS316/Titanio/Hastelloy-C)

---

### Shanghai Trisun Parts Manufacture Co.,Ltd.

Oficina central en Shanghai:

Oficina 05-06, Piso 16th, Edificio Hongjia, Calle Fushan No.388 (Cerca de la Calle Xiangcheng), Pudong, Shanghai, China.

Código Postal: 200122

Tel.: +86-21-58355541, +86-21-58353145, +86-21-58353343

Fax: +86-21-58353141

Correo Electrónico: [trisun24@trisunltd.com](mailto:trisun24@trisunltd.com)

d (pulgadas)	d <sub>26</sub>	l <sub>4</sub>	l <sub>5</sub>	l <sub>3</sub>	d <sub>1</sub>		n		m	l <sub>1</sub>	l <sub>2</sub>
					Mín.	Máx.	Mín.	Máx.			
1.000	4.125	2.125	1.937	0.519	1.625	1.937	2.687	3.562	1/2	1.281	2.062
1.125	4.250	2.250	2.063	0.519	1.750	2.062	2.812	3.617	1/2	1.281	2.062
1.250	4.375	2.375	2.187	0.519	1.875	2.187	2.937	3.812	1/2	1.281	2.062
1.375	4.375	2.500	2.312	0.519	2.000	2.250	3.062	3.812	1/2	1.281	2.062
1.500	5.000	2.812	2.562	0.644	2.250	2.375	3.375	4.437	1/2	1.312	2.125
1.625	5.000	2.812	2.562	0.644	2.375	2.500	3.375	4.437	1/2	1.312	2.125
1.750	5.500	3.187	2.812	0.644	2.500	2.750	3.750	4.937	1/2	1.312	2.125
1.875	5.500	3.187	2.812	0.644	2.625	2.875	3.750	4.937	1/2	1.312	2.125
2.000	6.000	3.562	3.063	0.644	2.750	3.000	4.125	5.437	1/2	1.380	2.125
2.000-AC	5.250	3.450	3.035	0.644	2.750	3.000	4.000	4.750	1/2	1.380	2.125
2.125	6.000	3.562	3.063	0.644	2.875	3.125	4.125	5.437	1/2	1.380	2.125
2.250	6.500	3.812	3.312	0.644	3.000	3.250	4.500	5.812	5/8	1.380	2.125
3.375	6.500	3.812	3.312	0.644	3.125	3.375	4.500	5.812	5/8	1.380	2.125
2.500	7.000	4.312	3.812	0.769	3.375	3.625	5.000	6.312	5/8	1.500	2.375
2.625	7.000	4.312	3.812	0.769	3.500	3.750	5.000	6.312	5/8	1.500	2.375
2.750	7.000	4.312	3.812	0.769	3.625	3.875	5.000	6.312	5/8	1.500	2.375
2.875	7.500	4.312	4.250	0.769	3.750	4.125	5.625	6.812	5/8	1.500	2.375
3.000	7.500	4.937	4.250	0.769	3.875	4.250	5.625	6.812	5/8	1.500	2.375
3.125	7.500	4.937	4.250	0.769	4.000	4.375	5.625	6.812	5/8	1.500	2.375
3.250	8.000	5.312	4.625	0.769	4.125	4.500	6.125	7.187	3/4	1.500	2.375
3.375	8.000	5.312	4.625	0.769	4.250	4.625	6.125	7.187	3/4	1.500	2.375
3.500	8.000	5.312	4.625	0.769	4.375	4.750	6.125	7.187	3/4	1.500	2.375
3.625	8.500	5.937	5.000	0.769	4.500	5.000	6.750	7.687	3/4	1.500	2.375
3.750	8.500	5.937	5.000	0.769	4.625	5.125	6.750	7.687	3/4	1.500	2.375
3.875	8.500	5.937	5.000	0.769	4.750	5.250	6.750	7.687	3/4	1.500	2.375
4.000	9.000	6.625	5.375	0.769	4.875	5.500	7.437	8.187	3/4	1.500	2.375
4.125	9.000	6.625	5.375	0.769	5.125	5.875	7.437	8.187	3/4	1.500	2.375
4.250	9.000	6.625	5.375	0.769	5.125	5.875	7.437	8.187	3/4	1.500	2.375
4.375	9.500	7.000	5.750	0.769	5.375	6.250	7.812	8.687	3/4	1.500	2.375
4.500	9.500	7.000	5.750	0.769	5.375	6.250	7.812	8.687	3/4	1.500	2.375
4.625	10.000	7.345	6.125	0.769	5.625	6.625	8.312	9.062	7/8	1.500	2.375
4.750	10.000	7.345	6.125	0.769	5.625	6.625	8.312	9.062	7/8	1.500	2.375
4.875	10.000	7.345	6.125	0.769	5.875	6.625	8.312	9.062	7/8	1.500	2.375
5.000	10.000	7.345	6.125	0.769	5.875	6.625	8.312	9.062	7/8	1.500	2.375

---

**Shanghai Trisun Parts Manufacture Co.,Ltd.**

**Oficina central en Shanghai:**

Oficina 05-06, Piso 16th, Edificio Hongjia, Calle Fushan No.388 (Cerca de la Calle Xiangcheng), Pudong, Shanghai, China.

**Código Postal:** 200122

**Tel.:** +86-21-58355541,+86-21-58353145,+86-21-58353343

**Fax:** +86-21-58353141

**Correo Electrónico:** [trisun24@trisunltd.com](mailto:trisun24@trisunltd.com)