

Sellos Mecánicos de Fuelle Metálico TSMB-A04 24mm-100mm

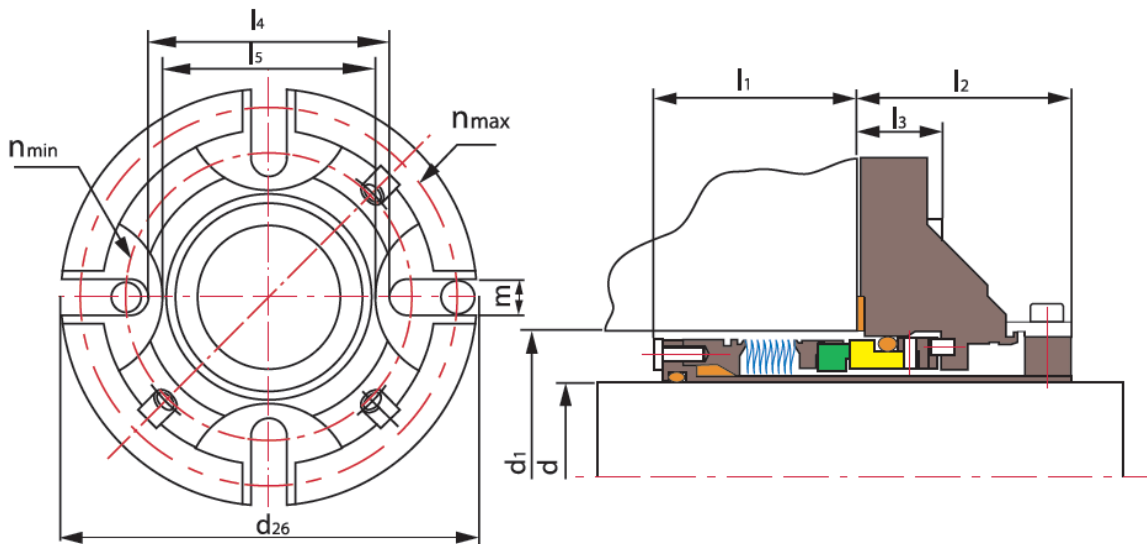

Límites de Funcionamiento

Presión: $\leq 2\text{MPa}$

Velocidad: $\leq 20\text{m/s}$

Temperatura: $-30^{\circ}\text{C} \sim +204^{\circ}\text{C}$

Anillo Rotatorio (SiC/Carbón/TC)

Anilla Estacionaria (SiC/TC)

Shanghai Trisun Parts Manufacture Co.,Ltd.

Oficina central en Shanghai:

Oficina 05-06, Piso 16th, Edificio Hongjia, Calle Fushan No.388 (Cerca de la Calle Xiangcheng), Pudong, Shanghai, China.

Código Postal: 200122

Tel.: +86-21-58355541,+86-21-58353145,+86-21-58353343

Fax: +86-21-58353141

Correo Electrónico: trisun24@trisunltd.com



Sello Secundario (VITON/Anillo Encapsulado/PTFE/Carbón Flexible)

Fuelles Metálicos (SUS316L/AM350/Inconel718/Titanio/Hastelloy-C/Aleación-20)

Otras Piezas (SUS304/SUS316/Titanio/Hastelloy-C)

d (mm)	d ₂₆	l ₄	l ₅	l ₃	d ₁		n		m	l ₁	l ₂
					Mín.	Máx.	Mín.	Máx.	max		
24	104.8	54.0	49.2	13.2	41.0	49.0	67.0	90.5	12	38.9	40.5
25	104.8	54.0	49.2	13.2	41.0	49.0	67.0	90.5	12	38.9	40.5
28	108.0	57.2	52.4	13.2	44.0	52.3	70.3	93.6	12	38.9	40.5
30	111.0	60.4	55.6	13.2	46.0	55.5	73.5	96.8	12	38.9	40.5
32	111.0	60.4	55.6	13.2	48.0	55.5	73.5	96.8	12	38.9	40.5
33	111.0	60.4	55.6	13.2	49.0	55.5	73.5	96.8	12	38.9	40.5
35	111.0	63.5	58.8	13.2	51.0	57.5	76.6	96.8	12	38.9	40.5
38	127.0	71.5	65.0	16.4	57.2	60.4	85.7	114.3	12	42.9	44.5
40	127.0	71.5	65.0	16.4	58.0	60.4	85.7	114.3	12	42.9	44.5
43	139.7	81.0	71.4	16.4	61.0	69.9	95.3	127.0	12	42.9	44.5
45	139.7	81.0	71.4	16.4	63.5	69.9	95.3	127.0	12	42.9	44.5
48	139.7	81.0	71.4	16.4	66.7	73.0	95.3	127.0	12	42.9	44.5
50	152.4	90.5	77.8	16.4	68.0	76.2	104.8	139.7	12	44.5	44.5
3	152.4	90.5	77.8	16.4	71.0	76.2	104.8	139.7	12	44.5	44.5
55	165.1	96.8	84.1	16.4	74.0	82.5	114.3	149.2	16	44.5	44.5
58	165.1	96.8	84.1	16.4	76.2	82.6	114.3	149.2	16	44.5	44.5
60	165.1	96.8	84.1	16.4	79.4	85.7	114.3	149.2	16	44.5	44.5
63	177.8	109.5	96.8	19.6	85.8	92.1	127.0	160.3	16	51.6	47.7
65	177.8	109.5	96.8	19.6	88.9	95.3	127.0	160.3	16	51.6	47.7
68	177.8	109.5	96.8	19.6	92.1	98.4	127.0	160.3	16	51.6	47.7
70	177.8	109.5	96.8	19.6	92.1	98.4	127.0	160.3	16	51.6	47.7
75	190.5	125.4	108.0	19.6	98.5	108.0	142.9	173.0	16	54.6	47.7
80	190.5	125.4	108.0	19.6	101.6	111.1	142.9	173.0	16	54.6	47.7
85	203.2	135.0	117.5	19.6	108.0	117.5	155.6	182.5	20	54.6	47.7
90	215.9	150.8	127.0	19.6	114.3	127.0	171.5	195.2	20	54.6	47.7
95	215.9	150.8	127.0	19.6	117.5	130.2	171.5	195.2	20	54.6	47.7
100	228.6	168.3	136.5	19.6	123.9	139.7	188.9	207.9	20	54.6	47.7

Shanghai Trisun Parts Manufacture Co.,Ltd.

Oficina central en Shanghai:

Oficina 05-06, Piso 16th, Edificio Hongjia, Calle Fushan No.388 (Cerca de la Calle Xiangcheng), Pudong, Shanghai, China.

Código Postal: 200122

Tel.: +86-21-58355541,+86-21-58353145,+86-21-58353343

Fax: +86-21-58353141

Correo Electrónico: trisun24@trisunltd.com