

Sello Mecánico TS MG1(TSG)8mm-100mm

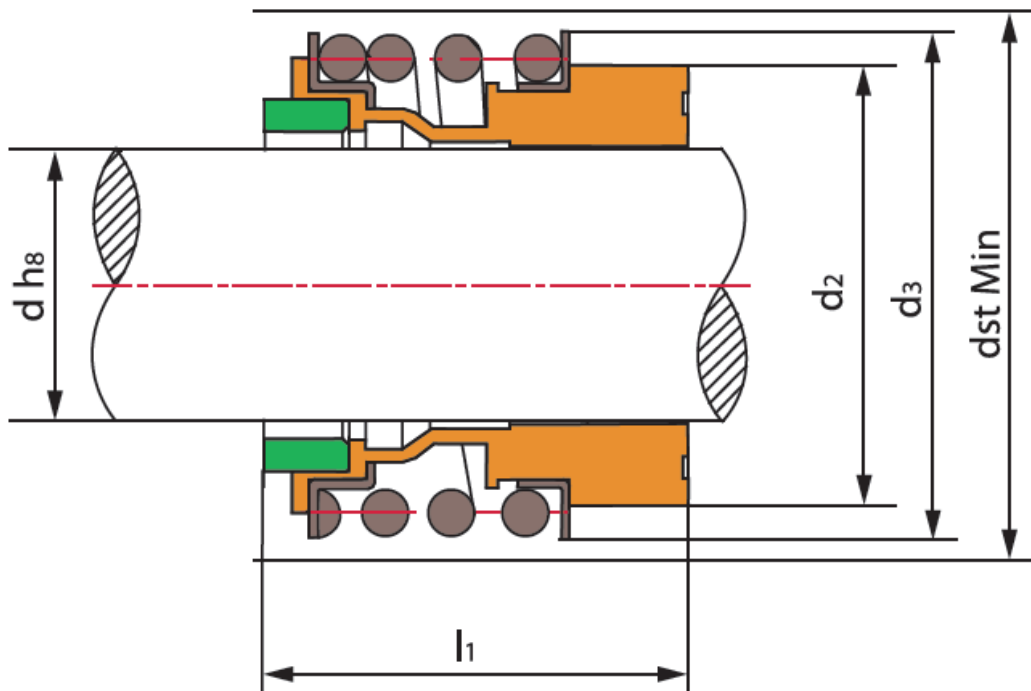

- Anillo Rotatorio (Carbón/Sic/TC)
- Anilla Estacionaria (Cerámica/Sic/TC)
- Sello Secundario (NBR/Epdm/VITON)
- Muelles y Otras Piezas (Sus304/Sus316)

Límites de Funcionamiento:

- Presión: $\leq 1.2\text{MPa}$
- Velocidad: $\leq 10\text{m/s}$
- Temperatura: $-20^{\circ}\text{C} \sim +120^{\circ}\text{C}$

Shanghai Trisun Parts Manufacture Co.,Ltd.

Oficina central en Shanghai:

Oficina 05-06, Piso 16th, Edificio Hongjia, Calle Fushan No.388 (Cerca de la Calle Xiangcheng), Pudong, Shanghai, China.

Código Postal: 200122

Telf.: +86-21-58355541,+86-21-58353145,+86-21-58353343

Fax: +86-21-58353141

Correo Electrónico: trisun24@trisunltd.com

Tamaño del Sello d(mm)	d	d ₂	d _{st}	d ₃	l ₁
ss10	10	20.5	24.0	22.5	25.9
12	12	22.5	26.0	25.0	25.9
14	14	26.5	30.0	28.5	28.4
16	16	26.5	30.0	28.5	28.4
18	18	29.0	33.0	32.0	30.0
20	20	33.0	38.0	37.0	30.0
22	22	33.0	38.0	37.0	30.0
24	24	38.0	44.0	42.5	32.5
25	25	38.0	44.0	42.5	32.5
28	28	44.0	50.0	49.0	35.0
30	30	44.0	50.0	49.0	35.0
32	32	46.0	55.0	53.5	35.0
33	33	46.0	55.0	53.5	35.0
35	35	50.0	59.0	57.0	35.0
38	38	53.0	61.0	59.0	36.0
40	40	55.0	64.0	62.0	36.0
43	43	58.0	67.0	65.5	36.0
45	45	60.0	70.0	68.0	36.0
48	48	63.0	74.0	70.5	36.0
50	50	65.0	77.0	74.0	38.0
53	53	70.0	81.0	78.5	36.5
55	55	72.0	83.0	81.0	36.5
58	58	75.0	88.0	85.5	41.5
60	60	79.0	91.0	88.5	41.5
65	65	84.0	96.0	93.5	41.5
68	68	88.0	100.0	96.5	41.2
70	70	90.0	103.0	99.5	48.7
75	75	95.0	110.0	107.0	48.7
80	80	100.0	116.0	112.0	48.0
85	85	107.0	124.0	120.0	46.0
90	90	114.0	131.0	127.0	51.0
95	95	119.0	136.0	132.0	51.0
100	100	124.0	140.0	137.0	51.0

Shanghai Trisun Parts Manufacture Co.,Ltd.

Oficina central en Shanghai:

Oficina 05-06, Piso 16th, Edificio Hongjia, Calle Fushan No.388 (Cerca de la Calle Xiangcheng), Pudong, Shanghai, China.

Código Postal: 200122

Telf.: +86-21-58355541,+86-21-58353145,+86-21-58353343

Fax: +86-21-58353141

Correo Electrónico: trisun24@trisunltd.com