

Sello Mecánico TS MG1 (TSG) 8mm-100mm

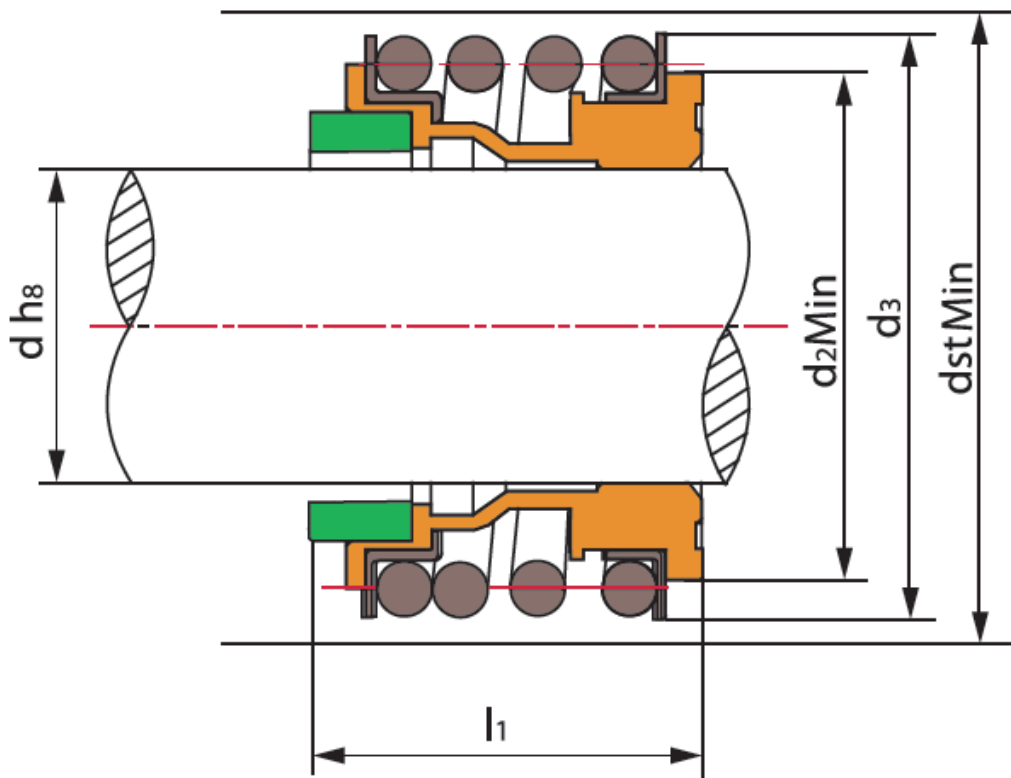

Anillo Rotatorio (Carbón/Sic/TC)
Anilla Estacionaria (Cerámica/Sic/TC)
Sello Secundario (NBR/EPDM/VITON)
Muelles y Otras Piezas (SUS304/SUS316)

Límites de Funcionamiento

Pressure: $\leq 1.2\text{MPa}$
Velocidad: $\leq 10\text{m/s}$
Temperatura: $-20^{\circ}\text{C} \sim +120^{\circ}\text{C}$

Shanghai Trisun Parts Manufacture Co.,Ltd.

Oficina central en Shanghai:

Oficina 05-06, Piso 16th, Edificio Hongjia, Calle Fushan No.388 (Cerca de la Calle Xiangcheng), Pudong, Shanghai, China.

Código Postal: 200122

Telf.: +86-21-58355541,+86-21-58353145,+86-21-58353343

Fax: +86-21-58353141

Correo Electrónico: trisun24@trisunltd.com

TSMG1					
Tamaño del Sello d(mm)	d	d ₂	d ₃	dst	l ₁
8	8	17.5	19.0	23.0	12.5
10	10	20.5	22.5	24.0	14.5
12	12	22.5	25.0	26.0	15.0
14	14	26.5	28.5	30.0	17.0
15	15	26.5	28.5	30.0	17.0
16	16	26.5	28.5	30.0	17.0
18	18	29.0	32.0	33.0	19.5
19	19	33.0	37.0	38.0	21.5
20	20	33.0	37.0	38.0	21.5
22	22	33.0	37.0	38.0	21.5
24	24	38.0	42.5	44.0	22.5
25	25	38.0	42.5	44.0	23.0
28	28	44.0	49.0	50.0	26.5
30	30	44.0	49.0	50.0	26.5
32	32	46.0	53.5	55.0	27.5
33	33	46.0	53.5	55.0	27.5
35	35	50.0	57.0	59.0	28.5
38	38	53.0	59.0	61.0	30.0
40	40	55.0	62.0	64.0	30.0
42	42	58.0	65.5	67.0	30.0
43	43	58.0	65.5	67.0	30.0
45	45	60.0	68.0	70.0	30.0
48	48	63.0	70.5	74.0	30.5
50	50	65.0	74.0	77.0	30.5
53	53	70.0	78.5	81.0	33.0
55	55	72.0	81.0	83.0	35.0
58	58	75.0	85.5	88.0	37.0
60	60	79.0	88.5	91.0	38.0
65	65	84.0	93.5	96.0	40.0
68	68	88.0	96.5	100.0	40.0
70	70	90.0	99.5	103.0	40.0
75	75	95.0	107.0	110.0	40.0
80	80	100.0	112.0	116.0	40.0
85	85	107.0	120.0	124.0	41.0
90	90	114.0	127.0	131.0	45.0
95	95	119.0	132.0	136.0	46.0
100	100	124.0	137.0	140.0	47.0

Shanghai Trisun Parts Manufacture Co.,Ltd.

Oficina central en Shanghai:

Oficina 05-06, Piso 16th, Edificio Hongjia, Calle Fushan No.388 (Cerca de la Calle Xiangcheng), Pudong, Shanghai, China.

Código Postal: 200122

Telf.: +86-21-58355541,+86-21-58353145,+86-21-58353343

Fax: +86-21-58353141

Correo Electrónico: trisun24@trisunltd.com

TSMG12					
Tamaño de Sello d(mm)	d	d ₂	d _{st}	d ₃	l ₁
10	10	20.5	24.0	22.5	25.9
12	12	22.5	26.0	25.0	25.9
14	14	26.5	30.0	28.5	28.4
16	16	26.5	30.0	28.5	28.4
18	18	29.0	33.0	32.0	30.0
20	20	33.0	38.0	37.0	30.0
22	22	33.0	38.0	37.0	30.0
24	24	38.0	44.0	42.5	32.5
25	25	38.0	44.0	42.5	32.5
28	28	44.0	50.0	49.0	35.0
30	30	44.0	50.0	49.0	35.0
32	32	46.0	55.0	53.5	35.0
33	33	46.0	55.0	53.5	35.0
35	35	50.0	59.0	57.0	35.0
38	38	53.0	61.0	59.0	36.0
40	40	55.0	64.0	62.0	36.0
43	43	58.0	67.0	65.5	36.0
45	45	60.0	70.0	68.0	36.0
48	48	63.0	74.0	70.5	36.0
50	50	65.0	77.0	74.0	38.0
53	53	70.0	81.0	78.5	36.5
55	55	72.0	83.0	81.0	36.5
58	58	75.0	88.0	85.5	41.5
60	60	79.0	91.0	88.5	41.5
65	65	84.0	96.0	93.5	41.5
68	68	88.0	100.0	96.5	41.2
70	70	90.0	103.0	99.5	48.7
75	75	95.0	110.0	107.0	48.7
80	80	100.0	116.0	112.0	48.0
85	85	107.0	124.0	120.0	46.0
90	90	114.0	131.0	127.0	51.0
95	95	119.0	136.0	132.0	51.0
100	100	124.0	140.0	137.0	51.0

Shanghai Trisun Parts Manufacture Co.,Ltd.

Oficina central en Shanghai:

Oficina 05-06, Piso 16th, Edificio Hongjia, Calle Fushan No.388 (Cerca de la Calle Xiangcheng), Pudong, Shanghai, China.

Código Postal: 200122

Telf.: +86-21-58355541,+86-21-58353145,+86-21-58353343

Fax: +86-21-58353141

Correo Electrónico: trisun24@trisunltd.com