

Sellos Mecánicos para Bombas Industriales TS CR

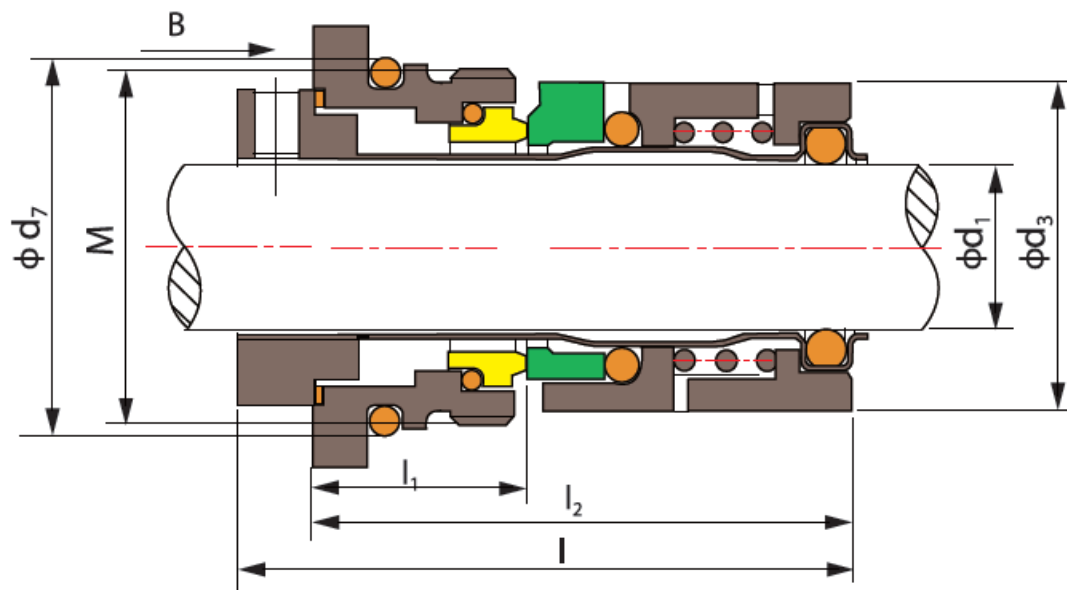

TS CR-12,16 PUNCHING TYPE

Shanghai Trisun Parts Manufacture Co.,Ltd.

Oficina central en Shanghai:

Oficina 05-06, Piso 16th, Edificio Hongjia, Calle Fushan No.388 (Cerca de la Calle Xiangcheng), Pudong, Shanghai, China.

Código Postal: 200122

Telf.: +86-21-58355541,+86-21-58353145,+86-21-58353343

Fax: +86-21-58353141

Correo Electrónico: trisun24@trisunltd.com

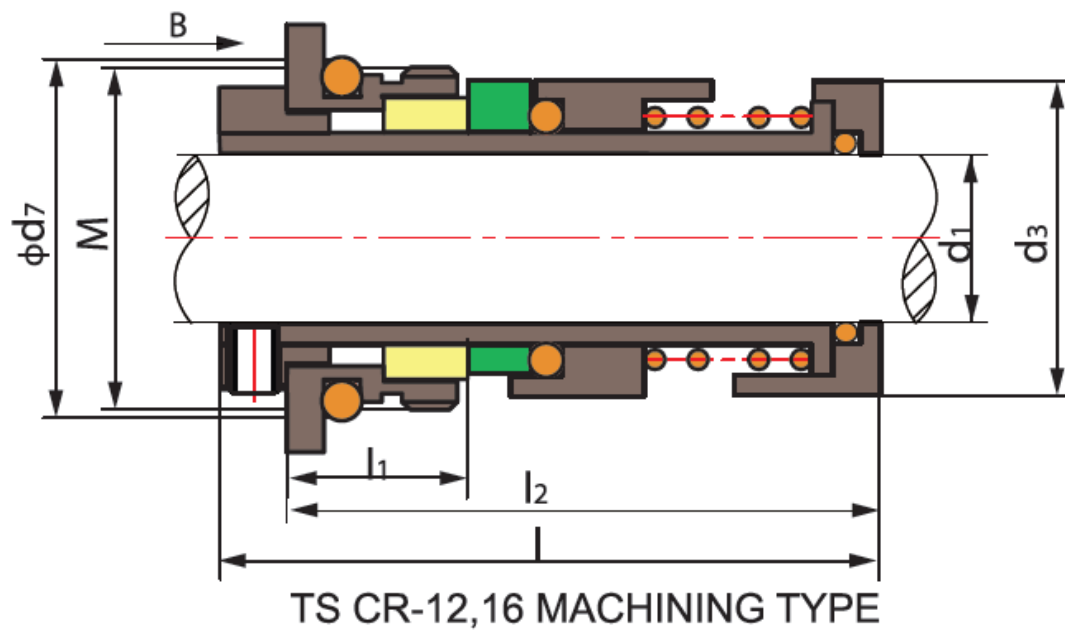
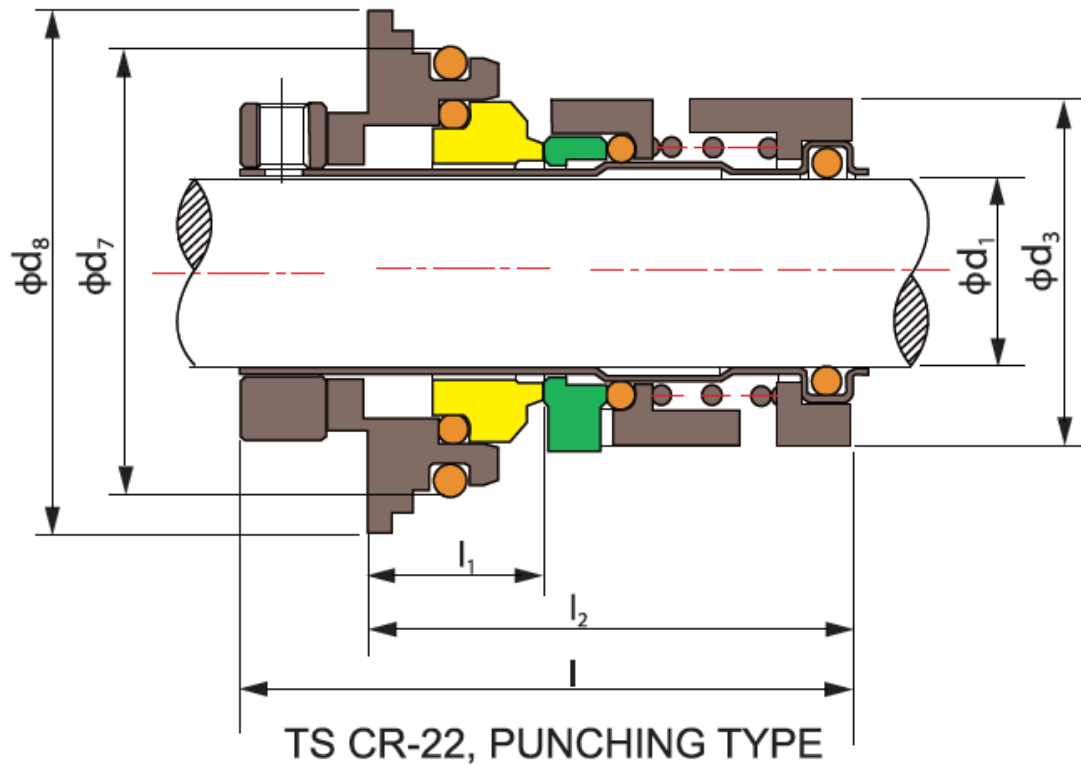

Shanghai Trisun Parts Manufacture Co.,Ltd.

Oficina central en Shanghai:

Oficina 05-06, Piso 16th, Edificio Hongjia, Calle Fushan No.388 (Cerca de la Calle Xiangcheng), Pudong, Shanghai, China.

Código Postal: 200122

Telf.: +86-21-58355541,+86-21-58353145,+86-21-58353343

Fax: +86-21-58353141

Correo Electrónico: trisun24@trisunltd.com

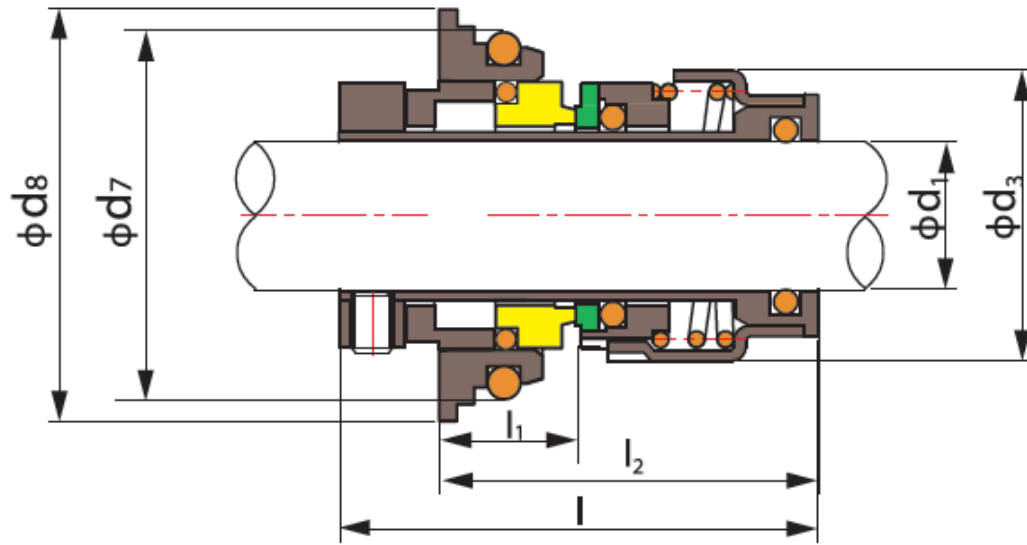

TS CR-22 MACHINING TYPE

Límites de Funcionamiento:

Presión: $\leq 1.0\text{MPa}$

Velocidad: $\leq 10\text{m/s}$

Temperatura: $-30^{\circ}\text{C} \sim +180^{\circ}\text{C}$

1. Anillo Rotatorio (SiC/TC)
2. Anilla Estacionaria (SiC/TC)
3. Sello Secundario (NBR/VITON)
4. Muelles y Otras Piezas (SUS304/SUS316)

Modelo	d ₁	d ₃	d ₇	d ₈	M	l	l ₁	l ₂	S
CR-12	12	25.0	29	\	M28×1.5	55	19	29.0	35.8
CR-16	16	30.5	34	\	M33×1.5	57.5	20	30.5	40.8
PUNZÓN CR-22	22	39	50	59	\	70.0	20	55.0	\
MECANIZACIÓN CR-22	22	42	50	60	\	70.0	20	55.0	\

Shanghai Trisun Parts Manufacture Co.,Ltd.

Oficina central en Shanghai:

Oficina 05-06, Piso 16th, Edificio Hongjia, Calle Fushan No.388 (Cerca de la Calle Xiangcheng), Pudong, Shanghai, China.

Código Postal: 200122

Telf.: +86-21-58355541,+86-21-58353145,+86-21-58353343

Fax: +86-21-58353141

Correo Electrónico: trisun24@trisunltd.com